

PolyPlumb® Push-Fit Plumbing System.

For over 25 years, PolyPlumb® has served as a tried and tested staple of the residential plumbing market. Our original, robust and reliable grey push-fit plumbing system, PolyPlumb® continues to be one of the most popular fittings for plumbing professionals.

As we strive to push the boundaries of innovative technology and progressive design, the PolyPlumb® system you know, and love has been improved. Now updated with a fresh new look and patented In-Cert® feedback technology, the new PolyPlumb® Enhanced fitting continues to deliver the reliability and confidence you've grown to expect from Polypipe Building Products.

PolyPlumb® fittings still feature the robust, stainless-steel grab ring, along with the same trusted pre-lubricated EPDM O ring that's always been at the heart of the fitting, ensuring continued joint integrity.

Feel it to believe it.

'The plumber's choice of classic, dependable grey push-fit system now looks better, feels better and performs better. Fit one of the patented In-Cert® Stiffeners into the Polypipe Polybutylene pipe end before inserting into the new PolyPlumb® fitting and the In-Cert Feedback Technology gives you confidence that the joint has been made. The head of the In-Cert® stiffener features patented geometry which combines with the fitting body to centralise the pipe, and, with a twist, you know that the pipe has been fully inserted. Push, twist, know.'

Use PolyPlumb® fittings and In-Cert® Stiffeners with Polypipe polybutylene flexible pipe, or you can combine PolyPlumb® fittings and copper pipe (no stiffener is needed with copper pipe).

Polypipe Building Products metal or plastic pipe stiffeners can still be used with polybutylene pipes and the new PolyPlumb® fitting, and you can also use the In-Cert® stiffener with the previous version of PolyPlumb® however you won't get the benefit of the In-Cert® insertion recognition technology with these combinations.

PolyPlumb® is suitable for use in most plumbing and heating installations, including hot and cold water and underfloor heating applications.



The system offers several benefits:

- Our enhanced grey push-fit plumbing system, using tried and tested technology for over 25 years.
- Now available in both grey and white fittings
- PolyPlumb® provides a superb combination of fast fitting with a permanent, reliable fix, now with patented In-Cert® feedback technology.
- PolyPlumb® offers a jointing process, with joint integrity assured by a robust stainless-steel grab ring.
- Secure; demountable by disassembly only. (Do not reuse the stainless-steel grab ring)
- Use for most hot and cold-water supply and heating applications, including underfloor heating.
- Use with Polypipe polybutylene pipe or copper pipe.
- Use with new patented In-Cert® feedback technology stiffeners for added confidence.
- 50-year guarantee.

Polypipe Building Products

Broomhouse Lane, Edlington, Doncaster, South
Yorkshire, DN12 1ES



+44 (0) 1709 770000



BP.Residential@polypipe.com



www.polypipe.com

Standards and Approvals

Polypipe meets, and constantly strives to exceed, the changing laws and regulations governing our operations and products.

We have invested in extensive testing and development facilities to ensure the products we supply are of the highest quality. Our plumbing systems conform to a number of third-party accredited standards, which are listed below.



British Standard Class S rated to BS7291 Part 1 and Kitemark Licence Number 38148 to BS7291 Part 1 and 2.



PolyPlumb® polybutylene barrier pipe systems are covered by BBA Certificate No. 00/3699.



The Water Supply (Water Fitting) Regulations 1999.

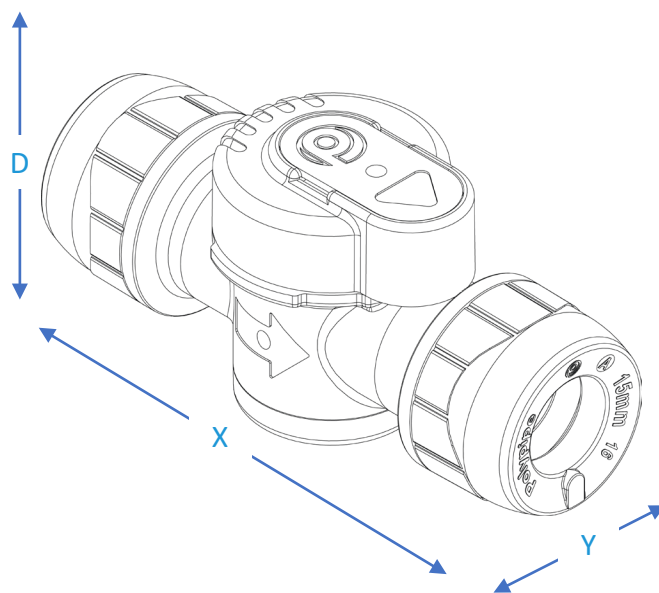

Design Information

	Value
Material(s)	ACETAL
Colour	White
Pipe Fitting System	Push-Fit

Dimensional Data

	PB5915
X	92mm,
Y	43mm
D	34mm

Technical Information

	PB5915
Pipe Fitting Product Type	Valve
Angle	N/A
Size	15mm x 15mm
Brand	PolyPlumb®
White EAN	5010924731572
Standard	BS 7291-1 & 2
Equal/Reducing	Equal
Guarantee	50 Years
Max. Pressure @ Max. Temperature	3 bar
Max. Pressure @ Min. Temperature	10 bar
Min. / Max. Operating Temperatures	2°C / 65°C
Pack Size	5

¹ Polypipe guarantees PolyPlumb® hot and cold-water supply and heating systems for 50 years against defects in materials or manufacture from date of purchase when installed in normal domestic applications. These guarantees only apply if the products are installed in accordance with the manufacturer's recommendations and are used in a normal domestic operation.