

We have dedicated testing facilities setting high industry standards, which allow certification testing to be undertaken in-house. This provides peace of mind for first fix testing.

### Exceeding expectations

- Pressure testing of stacks and products is available on request
- Combined with the wealth of experience provided by our Design and Manufacturing Teams, we will ensure all products delivered to site not only meet but exceed the expectations of installers and customers alike

### Key benefits to take from pre-air testing

We can pre-air test all our products before they leave the facility, which means there's a lot less that needs to be done on-site. If testing were to be completed on-site and it proved not to be airtight, it could cause setbacks that result in missed deadlines.

Weld on caps are fabricated on to soil and waste branches meaning that limited test bags and bungs are required on-site, making it significantly easier to achieve a successful first fix test.



TBUL-0003  
Version: 8  
Issued: 07/11/2024

If in doubt, ask - Technical: +44 (0) 1622 795200

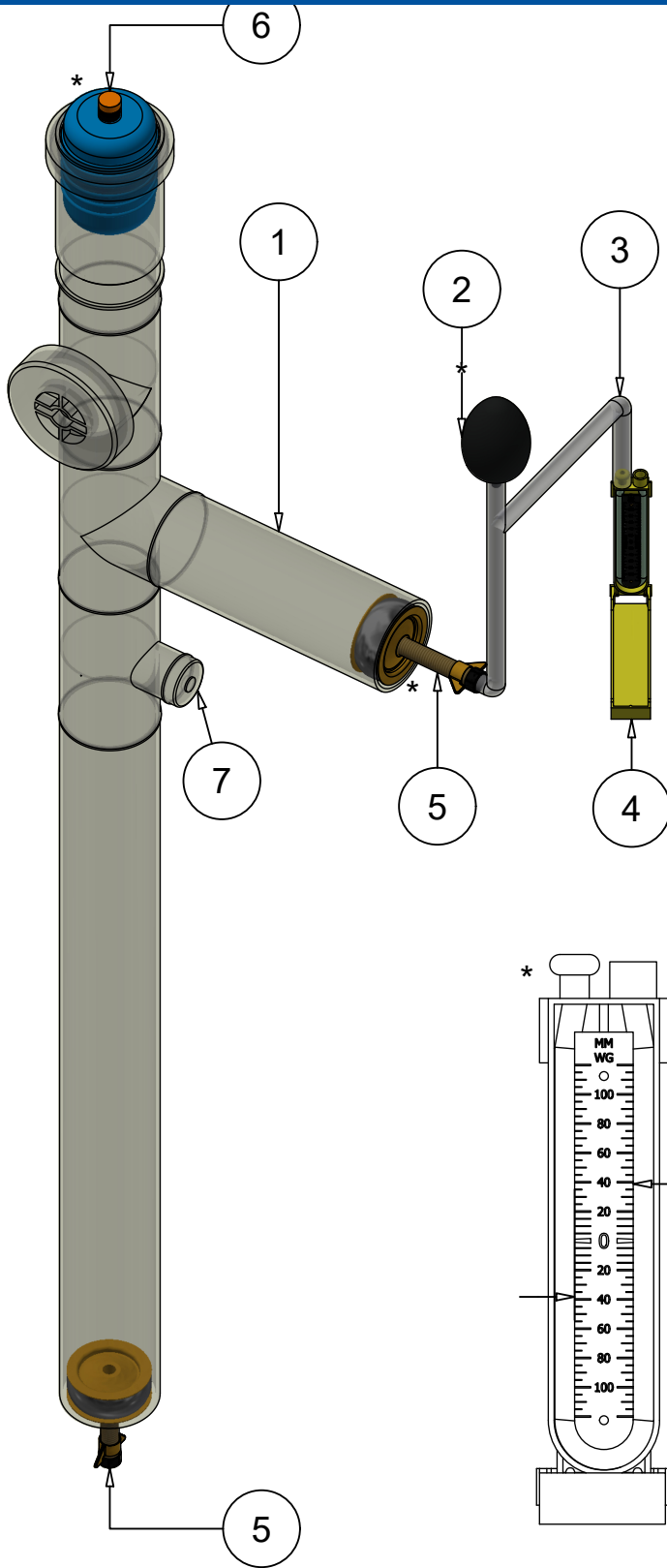

### Screwed Test Plug

- Blank or open
- For use in pipe ends
- Manufactured and supplied by others

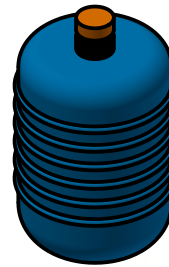

### Air bag

- Blank
- For use in access pipe/ expansion socket/ pipe ends
- Manufactured and supplied by others



### Canvas Style Air bag

- Flexible Blank
- For use in access pipe/ expansion socket/ pipe ends
- Manufactured and supplied by others



### 930 Weld on Cap

- Blank
- For use in pipe ends

\*For accurate readings, please ensure equipment is regularly checked.

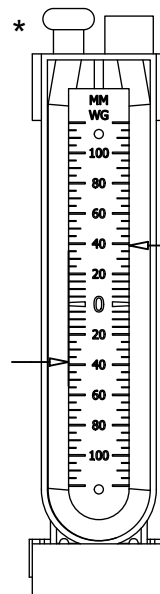

p = 38mm for no less than 3 mins.

No.	Part
1	Pipework to test
2	Bellow
3	Hose
4	U-Gauge (should read 38mm)
5	Screwed Test Plug
6	Air Bag
7	930 Weld on caps

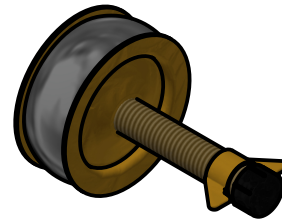
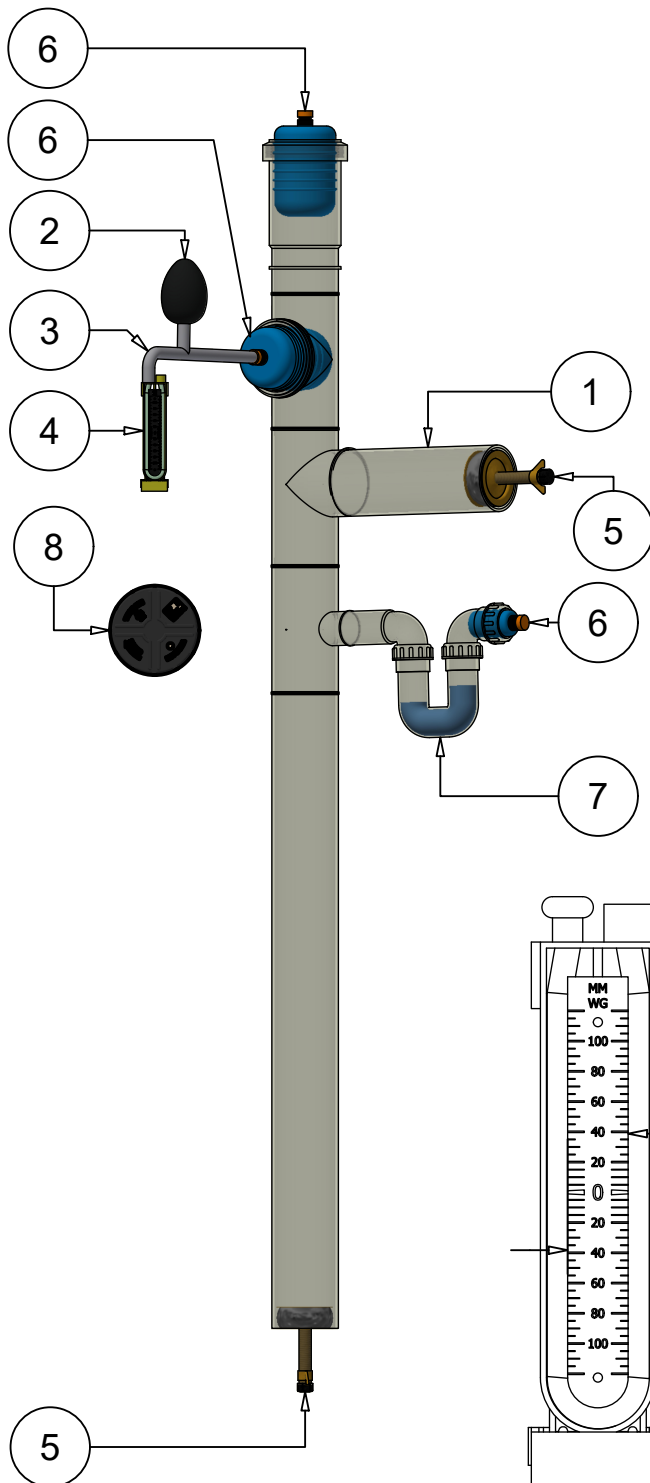

### Screwed Test Plug

- Rigid Blank or open
- For use in pipe ends
- Manufactured and supplied by others

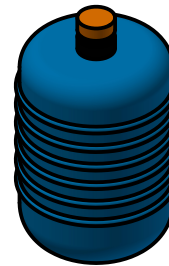

### PVC Style Air bag

- Semi-rigid Blank
- For use in access pipe/ expansion socket/ pipe ends
- Manufactured and supplied by others



### Canvas Style Air bag

- Flexible Blank
- For use in access pipe/ expansion socket/ pipe ends
- Manufactured and supplied by others

Traps must be filled with water to ensure there is positive pressure within the system to seal the waste inlet.

\*For accurate readings, please ensure equipment is regularly checked.

p = 38mm for no less than 3 mins.

No.	Part
1	Pipework to test
2	Bellow
3	Hose
4	U-Gauge (should read 38mm)
5	Screwed Test Plug
6	Air Bag
7	Trap (Must be filled with Water)
8	Screwed End Cap (For Access Door)

### What it states in BS EN 12056-2: 2000 (Annex NG.3.1)

#### NG.3 Testing

##### NG.3.1 Air test

NOTE Normally this test is carried out to confirm that all pipes and fittings are airtight. It should be completed in one operation but for large multi-storey systems testing in sections may be necessary.

##### NG.3.1.1 Preparation

The water seals of sanitary appliances should be fully charged and test plugs or bags inserted into the open ends of the pipework to be tested. To ensure that there is a satisfactory air seal at the base of the stack, or at the lowest plug or bag in the stack if only a section of the pipework is to be tested, a small quantity of water sufficient to cover the plug or bag can be allowed to enter the system. One of the remaining test plugs should be fitted with a tee piece, with a cock on each branch, and one branch being connected by means of a flexible tube to a manometer. Alternatively, a flexible tube from a tee piece fitted with cocks on its other two branches can be passed through the water seal of a sanitary appliance. Any water trapped in this tube should be removed and then a manometer can be connected to one of the branches.

##### NG.3.1.2 Application

Air is pumped into the system through the other branch of the tee piece until a pressure equal to 38 mm water gauge is obtained. The air inlet cock is then closed and pressure in the system should remain constant for a period of not less than 3 min.

##### NG.3.1.3 Leak location

NOTE Defects revealed by an air test may be located by the methods given in NG.3.1.3.1, NG.3.1.3.2 and NG.3.1.3.3.

##### NG.3.1.3.1 Smoke

A smoke producing machine may be used which will introduce smoke under any pressure into the defective pipework. Leakage may be observed as the smoke escapes. Smoke cartridges containing special chemicals should be used with caution, taking care that the ignited cartridge is not in direct contact with the pipework and that the products of combustion do not have a harmful effect upon the materials used for the discharge pipe system. Smoke testing of plastics pipework should be avoided due to naphtha having a detrimental effect, particularly on ABS, PVC-U and MUPVC. Rubber jointing components can also be adversely affected.

##### NG.3.1.3.2 Soap solution

With the pipework subject to an internal pressure using the smoke machine method as described in NG.3.1.3.1, a soap solution can be applied to the pipes and joints. Leakage can be detected by the formation of bubbles.

##### NG.3.1.3.3 Water test

There is no justification for a water test to be applied to the whole of the plumbing system. The part of the system mainly at risk is that below the lowest sanitary appliance, and this may be tested by inserting a test plug in the lower end of the pipe and filling the pipe with water up to the flood level of the lowest sanitary appliance, provided that the static head does not exceed 6 m.

\*For accurate readings, please ensure equipment is regularly checked.

Permission to reproduce extracts from BS EN 12056-2:2000 is granted by BSI. British Standards can be obtained in PDF or hard copy formats from the BSI online shop: [www.bsigroup.com/Shop](http://www.bsigroup.com/Shop) or by contacting BSI Customer Services for hardcopies only: Tel: +44 (0)20 8996 9001, Email: [cservices@bsigroup.com](mailto:cservices@bsigroup.com).

When purchasing the 927.110B or 911.110B, the current version of the product comes with a black temporary site plug.

This is made out of recycled HDPE and can be used to close off the fitting when air testing is accordance with BS EN 12056-2.

The previous site plug was blue. The blue plug was there solely as a dust cap to prevent ingress of dirt and cannot be used when air testing.

Note, this is only for 110mm sizes. (Part no. UG445)

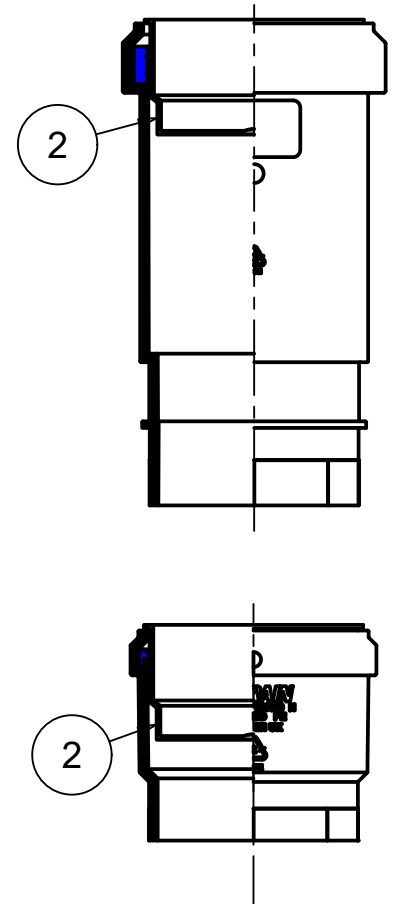
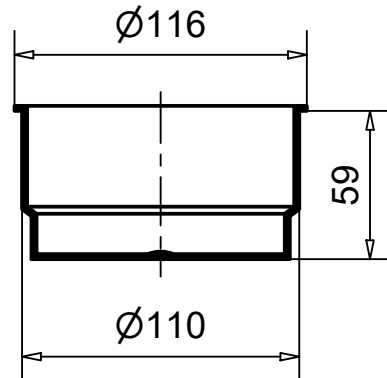

The other fittings still have the blue temporary site plugs where applicable and can be purchased separately, including the original 110mm blue cap.

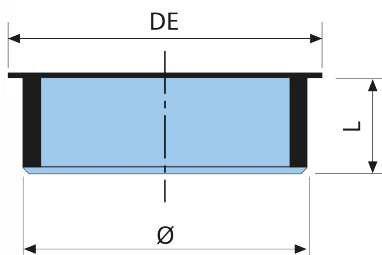
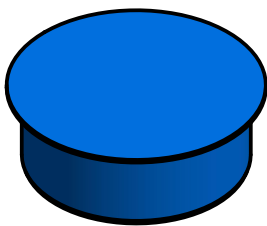

Ø	DE	L	Kg	Code
<b>HDPE PROTECTIVE CAP FOR SOCKET</b>				
56	62	25	0.01	9130.56B
63	71	38	0.015	9130.63B
75	85	38	0.02	9130.75B
90	102	38	0.03	9130.90B
110	123	39	0.04	9130.110B
125	135	38	0.055	9130.125B
160	167	36	0.055	9130.160B
200	220	50	0.13	9130.200B